

4ALL BASIN MD080BI

CE EN 14688:2015



Ceramic antibacterial effect
BATAFORM®



Glazed product with
CERASLIDE®

Cod. **MD080BI**

Basin 80.48 h15cm. Wall-hung installation or on base.
Fixing kit included. Weight 21 kg.

GLOBO

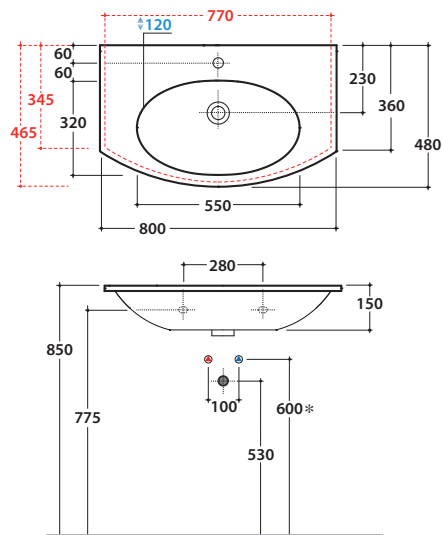

* For taps mounted on counter top



Cod. **FI012BI**

Push open valve drain with ceramic top for basins with overflow. Weight 0,5 Kg



Cod. **FI012CR**

Push open chromed valve drain for basins with overflow. Weight 0,5 Kg

Wall-hung base 78.48 h 49 cm. 2 drawers. Weight 28 Kg

Cod. **MDMC80Y**

Smoke 906
Desert 907

Lacquered
Laminate oak lacquered

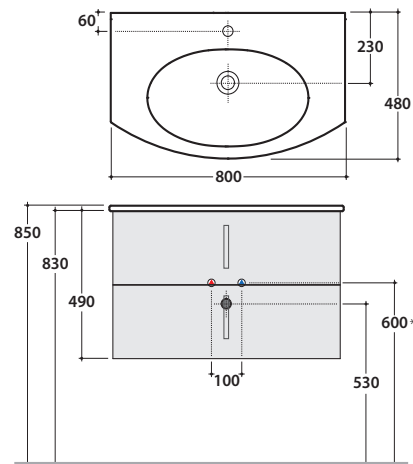
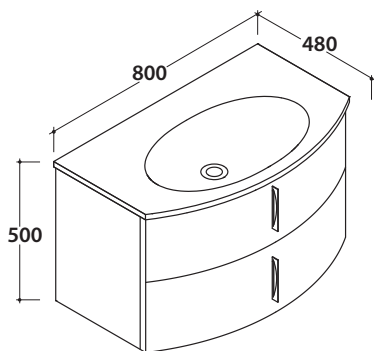

Maximum encumbrance with open drawer 940 mm

* For taps mounted on counter top

Wall-hung base 78.48 h 49 cm. 2 doors. Weight 28 Kg

Cod. **MDMA80Y**

Smoke 906
Desert 907

Lacquered
Laminate oak lacquered

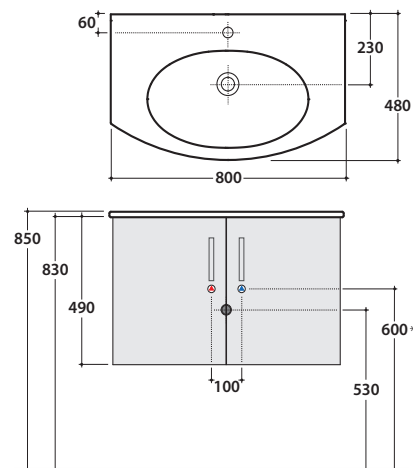
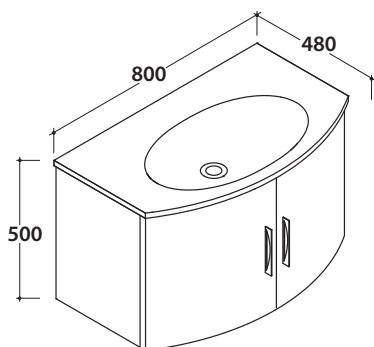

Maximum encumbrance with open door 940 mm

* For taps mounted on counter top